

# Lomo Eco Heat Pump



MODEL: TW09HQ1B2D

Project Name:

Location:

Engineer Name:

Purshaser:

Unit Designation:

Schedule No.

SubmittedTo:

Date:



### General Features

- Low Ambient Cooling to 0 F/-18 C
- Multiple Fan Speeds
- Memory Function
- Fan Delay Function
- Intelligent Pre-heating / Defrost
- Control lock

- Smart 1 Hertz Inverter Technology
- Load Protection Features
- Over-Current Protection
- Drain Pan Heater
- LED display

### Unit Performance:

Cooling:	-	-
Capacity (Min Rated Max, Btu/h)	2,457-9,100	9,600
SEER		17
EER		10.25
Heating:	-	-
Capacity (Min Rated Max, Btu/h)	2,457-9,500	11,500
HSPF		9
COP (W/W)		3.6

### Compressor

Cooling Operation Ambient temp. Range	-18~46 C
Heating Operation Ambient temp. Range	-20~24 C
Compressor Type	Rotary
Compressor RLA (A)	6.6
Crankcase Heater	Yes

### Electrical Specification

Power Supply	208-230V / 60Hz
Communications Wire Size	AWG 14
MOP (A)	15
MCA (A)	10
Cooling Rated Amps (A)	4.3
Heating Rated Amps (A)	3.8
Indoor Fan Motor RLA (A)	0.22
Outdoor Fan Motor RLA(A)	0.37
Nominal Cooling Power Input (kW)	0.9
Nominal Heating Power Input (kW)	0.8

### Unit Specification

Refrigerant Type	R410A
Refrigerant Charge (oz)	24
ODU Sound Pressure (dB(A))	50
IDU Sound Pressure (dB(A))	39/37/33/26
ODU Net Weight (lbs)	58.4
IDU Net Weight (lbs)	19.8
Dehumidifying (Pint/D)	1.69

### Fan

ODU / IDU Type	Axial-flow/Cross-flow
Fan Motor Output (W)	30
Motor/Drive	Direct Drive
ODU Max Air Flow Rate (CFM)	941.7
IDU Air Flow Rate (CFM)	182/294

### Piping

Liquid Line (in, OD)	1/4
Gas Line (in, OD)	3/8
Additional Refrigerant (oz./ft.)	0.2
Max Pipe Length (ft.)	49.2
Piping Length (with factory charge, ft.)	24.6
Max Elevation (ft.)	32.8



AHRI certification Ref #

Lomo Eco Heat Pump



MODEL: TW09HQ1B2D

Lomo Eco Heat Pump

**TOSOT**

MODEL: TW09HQ1B2D

Outline Dimension Diagram

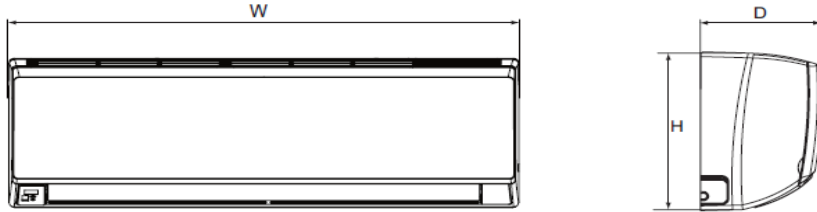

W	H	D
37 1/8	10 7/8	7 7/8

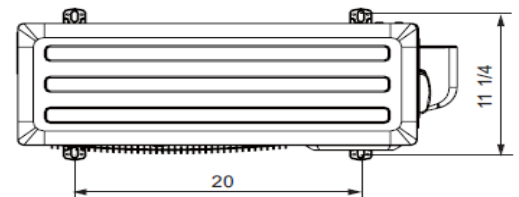
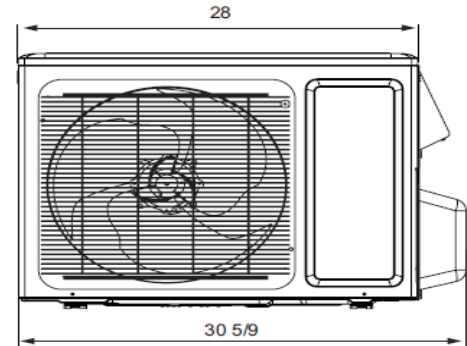
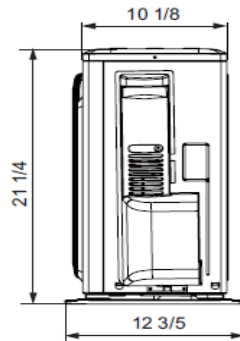
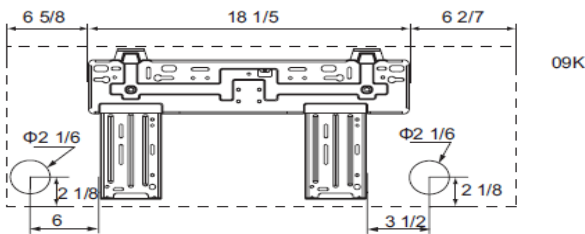

Approved By:

Signature

Date

**TOSOT**

315 Boulevard Industriel, Châteauguay, QC, Canada J6J 4Z2

Contact: +1 (450) 698-4000

[info@tosotamerica.com](mailto:info@tosotamerica.com)

[tosotamerica.com](http://tosotamerica.com)